

Introduction

In the next part of the course, we will be working with the **Scheme** programming language. In addition to learning how to write Scheme programs, we will eventually write a Scheme interpreter in Project 4!

Scheme is a famous functional programming language from the 1970s. It is a dialect of Lisp (which stands for LISt Processing). The first observation most people make is the unique syntax, which uses a prefix notation and (often many) nested parentheses (see <http://xkcd.com/297/>). Scheme features first-class functions and optimized tail-recursion, which were relatively new features at the time.

Primitives and Defining Variables

Scheme has a set of **atomic** primitive expressions. Atomic means that these expressions cannot be divided up.

```
scm> 123
123
scm> #t
True
scm> #f
False
```

Unlike in Python, the only primitive in Scheme that is a false value is `#f` and its equivalents, `false` and `False`. **This means that 0 is not false.**

In Scheme, we can use the `define` special form to bind values to symbols, which we can then use as variables. When a symbol is defined this way, the `define` special form returns the symbol.

- `(define <variable name> <value>)`

Evaluates `<value>` and binds the value to `<variable name>` in the current environment.

WWSD

```
scm> (define a 1)
```

```
scm> a
```

```
scm> (define b a)
```

```
scm> b
```

```
scm> (define c 'a)
```

```
scm> c
```

Call Expressions

Call expressions apply a procedure to some arguments.

```
(<operator> <operand1> <operand2> ...)
```

Call expressions in Scheme work exactly like they do in Python. To evaluate them:

1. Evaluate the operator to get a procedure.
2. Evaluate each of the operands from left to right.
3. Apply the value of the operator to the evaluated operands.

For example, consider the call expression `(+ 1 2)`. First, we evaluate the symbol `+` to get the built-in addition procedure. Then we evaluate the two operands `1` and `2` to get their corresponding atomic values. Finally, we apply the addition procedure to the values `1` and `2` to get the return value `3`.

Operators may be symbols, such as `+` and `*`, or more complex expressions, as long as they evaluate to procedure values.

Here is a reference for the [Scheme Built-In Procedures](#).

```
scm> (- 1 1)           ; 1 - 1
0
scm> (* (+ 1 2) (+ 1 2)) ; (1 + 2) * (1 + 2)
9
```

WWSD

What would Scheme display? As a reminder, the built-in `quotient` function performs floor division.

```
scm> (define a (+ 1 2))
```

```
scm> a
```

```
scm> (define b (- (+ (* 3 3) 2) 1))
```

```
scm> (+ a b)
```

```
scm> (= (modulo b a) (quotient 5 3))
```

Special Forms

Special form expressions contain a **special form** as the operator. Special form expressions *do not* follow the same rules of evaluation as call expressions. Each special form has its own rules of evaluation – that’s what makes them special! Here’s the [Scheme Specification](#) to reference the special forms we will cover in this class.

It is important to note that everything in Scheme is either an **atomic** or an **expression**, so although these special forms look and operate similarly to Python, they are evaluated differently.

Special forms like `if`, `cond`, `and`, or `or` in Python direct the control flow of a program and allow you to evaluate specific expressions under some condition. In Scheme, however, these special forms are expressions that take in a set amount of parameters and return some value based on the condition passed in.

If Expression

An `if` expression looks like this:

```
(if <predicate> <if-true> [if-false])
```

<predicate> and <if-true> are required expressions and [if-false] is optional.

The rules for evaluation are as follows:

1. Evaluate <predicate>.
2. If <predicate> evaluates to a truth-y value, evaluate <if-true> and return its value. Otherwise, evaluate [if-false] if provided and return its value.

`if` is a special form as not all of its operands will be evaluated. The value of the first operand determines whether the second or the third operator is evaluated.

Important: Only `#f` is a false-y value in Scheme; everything else is truth-y, including 0.

```
scm> (if (< 4 5) 1 2)
1
scm> (if #f (/ 1 0) 42)
42
```

Cond Expression

A `cond` expression looks like this:

```
(cond (<pred1> <if-pred1>) (<pred2> <if-pred2>) ... (<predn> <if-predn>) [(else <else-expression>)])
```

Must have at least one <predn> and <if-predn> and [(else <else-expression>)] is optional.

The rules for evaluation are as follows:

1. Evaluate the predicates `<pred1>`, `<pred2>`, ..., `<predn>` in order until you reach one that evaluates to a truth-y value.
2. If you reach a predicate that evaluates to a truth-y value, evaluate and return the corresponding expression in the clause.
3. If none of the predicates are truth-y and there is an else clause, evaluate and return `<else-expression>`.

`cond` is a special form because it does not evaluate its operands in their entirety; the predicates are evaluated separately from their corresponding return expression. In addition, the expression short circuits upon reaching the first predicate that evaluates to a truth-y value, leaving the remaining predicates unevaluated.

```
scm> (cond
      ((< 4 5) 1)
      (else 2)
      )
1
scm> (cond
      (#f (/ 1 0))
      (else 42)
      )
42
```

Let Expressions

A `let` expression looks like this: `(let ([binding_1] ... [binding_n]) <body> ...)`

Each `binding` corresponds to expressions of the form `(<name> <expression>)`.

Scheme evaluates a `let` expression using the following steps:

1. Create a new local frame that extends the current environment (in other words, it creates a new child frame whose parent is the current frame).
2. For each `binding` provided, bind each `name` to its corresponding evaluated `expression`.
3. Finally, the `body` expressions are evaluated in order in this new frame, returning the result of evaluating the last expression.

Note that bindings are optional within a `let` statement, but we typically include them.

```

scm> (let (
      (x 5)
      (y 10)
    )
      (print x)
      (print y)
      (- x y)
      (+ x y)
    )
5
10
15

```

Note that `(- x y)` in the body of this `let` expression *does* get evaluated, but the result doesn't get returned by the `let` expression because only the value of the *last* expression in the body, `(+ x y)`, gets returned. Thus, the interpreter does *not* display `-5` (the result of `(- x y)`).

However, we see that `5` and `10` *are* displayed out by the interpreter. This is because printing `5` and printing `10` were *side effects* of evaluating the expressions `(print x)` and `(print y)`, respectively. `5` and `10` are *not* the return values of `(print x)` and `(print y)`.

Begin Expressions

A `begin` expression looks like this: `(begin <body_1> ... <body_n>)`

Scheme evaluates a `begin` expression by evaluating each `body` in order in the current environment, returning the result of evaluating the last `body`.

```

scm> (begin
      (print (< 2 3))
      (print 'hello)
      (+ 1 2)
      (- 5 7)
    )
#t
hello
-2

```

Again, note that `(+ 1 2)` does get evaluated, but the result, `3`, does not get returned by the `begin` expression (and thus does not get displayed by the interpreter) because it is not the last `body` expression.

Boolean operators

Like Python, Scheme has the boolean operators `and`, `or`, and `not`. `and` and `or` are special forms because they are short-circuiting operators, while `not` is a builtin procedure.

- `and` takes in any amount of operands and evaluates these operands from left to right until one evaluates to a false-y value. It returns that first false-y value or the value of the last expression if there are no false-y values.

6 Scheme, Scheme Lists

- `or` also evaluates any number of operands from left to right until one evaluates to a truth-y value. It returns that first truth-y value or the value of the last expression if there are no truth-y values.
- `not` takes in a single operand, evaluates it, and returns its opposite truthiness value.

```
scm> (and 25 32)
32
scm> (or 1 (/ 1 0)) ; Short-circuits
1
scm> (not (odd? 10))
#t
```

WWSD

What would Scheme display?

```
scm> (if (or #t (/ 1 0)) 1 (/ 1 0))
```

```
scm> ((if (< 4 3) + -) 4 100)
```

```
scm> (cond
      ((and (- 4 4) (not #t)) 1)
      ((and (or (< 9 (/ 100 10)) (/ 1 0)) #t) -1)
      (else (/ 1 0))
      )
```

```
scm> (let (
      (a (- 3 2))
      (b (+ 5 7))
      )
      (* a b)
      (if (< (+ a b) b)
          (/ a b)
          (/ b a)
      )
      )
```

```
scm> (begin
      (if (even? (+ 2 4))
          (print (and 2 0 3))
          (/ 1 0))
      )
      (+ 2 2)
      (print 'lisp)
      (or 2 0 3)
      )
```

Defining Functions

All Scheme procedures are constructed as lambda procedures.

One way to create a procedure is to use the `lambda` special form.

```
(lambda (<param1> <param2> ...) <body>)
```

This expression creates a lambda function with the given parameters and body, but does not evaluate the body. As in Python, the body is not evaluated until the function is called and applied to some argument values. The fact that neither the parameters nor the body is evaluated is what makes `lambda` a special form.

We can also assign the value of an expression to a name with a `define` special form:

1. `(define (<name> <param> ...) <body> ...)`
2. `(define <name> (lambda (<param> ...) <body> ...))`

These two expressions are equivalent; the first is a concise version of the second.

```
scm> ; Bind lambda function to square
scm> (define square (lambda (x) (* x x)))
square
scm> (define (square x) (* x x))           ; Same as above
square
scm> square
(lambda (x) (* x x))
scm> (square 4)
16
```

Q1: Virahanka-Fibonacci

Write a function that returns the n -th Virahanka-Fibonacci number.

```
(define (vir-fib n)
  'YOUR-CODE-HERE

)

(expect (vir-fib 10) 55)
(expect (vir-fib 1) 1)

# You can use more space on the back if you want
```

```
scm> (vir-fib 0)
0
scm> (vir-fib 1)
1
scm> (vir-fib 10)
55
```

Pairs and Lists

All lists in Scheme are linked lists. Scheme lists are composed of two element pairs. We define a list as being either

- the empty list, `nil`
- a pair whose second element is a list

As in Python, linked lists are recursive data structures. The base case is the empty list.

We use the following procedures to construct and select from lists:

- `(cons first rest)` constructs a list with the given first element and rest of the list. For now, if `rest` is not a pair or `nil` it will error.
- `(car lst)` gets the first item of the list
- `(cdr lst)` gets the rest of the list

To visualize Scheme lists, you can use the `draw` function in code.cs61a.org.

```
scm> nil
()
scm> (define lst (cons 1 (cons 2 (cons 3 nil))))
lst
scm> lst
(1 2 3)
scm> (car lst)
1
scm> (cdr lst)
(2 3)
```

Scheme lists are displayed in a similar way to the `Link` class we defined in Python. [Here is an example in 61A Code](#).

Two other ways of creating lists are using the built-in `list` procedure or the `quote` special form.

The `list` procedure has the syntax `(list <item> ...)`. It takes in an arbitrary number of operands and constructs a list with their values.

```
scm> (list 1 2 3)
(1 2 3)
```

The `quote` special form has the syntax `(quote <expression>)`. It returns the literal `expression` without evaluating it. A shorthand for the `quote` special form is `'<expression>`.

```
scm> (define a 61)
a
scm> a
61
scm> (quote a)
a
scm> 'a
a
```

We can use the `quote` form to create a list by passing in a combination as the `expression`:

```
scm> (quote (1 x 3))
(1 x 3)
scm> '(1 x 3) ; Equivalent to the previous quote expression
(1 x 3)
```

An important difference between `list` (along with `cons`) and `quote` is that `list` and `cons` evaluate each of their operands before putting them into a list, while `quote` will return the list exactly as typed, without evaluating any of the individual elements.

```
scm> (define a 1)
a
scm> (define b 2)
b
scm> (list a b 3)
(1 2 3)
scm> '(a b 3)
(a b 3)
```

Note that if we wanted to create the list `(a b 3)` using the `list` procedure, we could quote the symbols `a` and `b` so that they are not evaluated when making the list:

```
scm> (list 'a 'b 3)
(a b 3)
```

`=`, `eq?`, `equal?`

- `(= <a>)` returns true if `a` equals `b`. Both must be numbers.
- `(eq? <a>)` returns true if `a` and `b` are equivalent primitive values. For two objects, `eq?` returns true if both refer to the same object in memory. Similar to checking identity between two objects using `is` in Python
- `(equal? <a>)` returns true if `a` and `b` are *pairs* that have the same contents (`cars` and `cdrs` are equivalent). Similar to checking equality between two lists using `==` in Python. If `a` and `b` are not pairs, `equal?` behaves like `eq?`.

```
scm> (define a '(1 2 3))
a
scm> (= a a)
Error
scm> (equal? a '(1 2 3))
#t
scm> (eq? a '(1 2 3))
#f
```

WWSD

What would Scheme display?

```
scm> (cons 1 (cons 2 nil))
```

```
scm> (car (cons 1 (cons 2 nil)))
```

```
scm> (cdr (cons 1 (cons 2 nil)))
```

```
scm> (list 1 2 3)
```

```
scm> '(1 2 3)
```

```
scm> (cons 1 '(list 2 3)) ; Recall quoting
```

```
scm> '(cons 4 (cons (cons 6 8) ()))
```

```
scm> (cons 1 (list (cons 3 nil) 4 5))
```

Q2: List Making

Let's make some Scheme lists. We'll define the same list with `list`, `quote`, and `cons`.

The following list was visualized using the `draw` feature of `code.cs61a.org`.

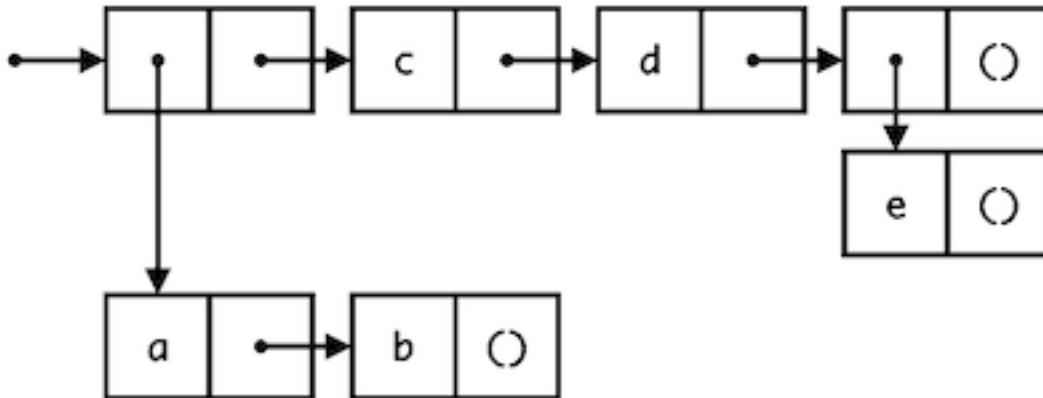

First, use `list`:

```
(define with-list
  (list
    'YOUR-CODE-HERE

  )
)
(draw with-list)
```

You can use more space on the back if you want

Now use `quote`. What differences are there?

```
(define with-quote
  '(
    'YOUR-CODE-HERE

  )
)
(draw with-quote)

# You can use more space on the back if you want
```

Now try with `cons`. For convenience, we've defined a `helpful-list` and `another-helpful-list`:

```
(define helpful-list
  (cons 'a (cons 'b nil)))
(draw helpful-list)

(define another-helpful-list
  (cons 'c (cons 'd (cons (cons 'e nil) nil))))
(draw another-helpful-list)

(define with-cons
  (cons
    'YOUR-CODE-HERE

  )
)
(draw with-cons)

# You can use more space on the back if you want
```

Q3: List Concatenation

Write a function which takes two lists and concatenates them.

Notice that simply calling `(cons a b)` would not work because it will create a deep list. Do not call the builtin procedure `append`, since it does the same thing as `list-concat` should do.

```
(define (list-concat a b)
  'YOUR-CODE-HERE

)

(expect (list-concat '(1 2 3) '(2 3 4)) (1 2 3 2 3 4))
(expect (list-concat '(3) '(2 1 0)) (3 2 1 0))

# You can use more space on the back if you want
```

```
scm> (list-concat '(1 2 3) '(2 3 4))
(1 2 3 2 3 4)
```

Q4: Remove

Implement a procedure `remove` that takes in a list and returns a new list with *all* instances of `item` removed from `lst`. You may assume the list will only consist of numbers and will not have nested lists.

Hint: You might find the built-in `filter` procedure useful (though it is definitely possible to complete this question without it).

You can find information about how to use `filter` in the [61A Scheme builtin specification!](#)

```
(define (remove item lst)
  'YOUR-CODE-HERE

)

(expect (remove 3 nil) ())
(expect (remove 2 '(1 3 2)) (1 3))
(expect (remove 1 '(1 3 2)) (3 2))
(expect (remove 42 '(1 3 2)) (1 3 2))
(expect (remove 3 '(1 3 3 7)) (1 7))

# You can use more space on the back if you want
```

Additional Practice

Q5: List Duplicator

Write a Scheme function, `duplicate` that, when given a list, such as `(1 2 3 4)`, duplicates every element in the list (i.e. `(1 1 2 2 3 3 4 4)`).

```
(define (duplicate lst)
  'YOUR-CODE-HERE

)

(expect (duplicate '(1 2 3)) (1 1 2 2 3 3))
(expect (duplicate '(1 1)) (1 1 1 1))

# You can use more space on the back if you want
```